

Signature **Multix**

Guy Bonneville
BLAM
DRIVEN BY PASSION

WS 6

HIGH POWER WOOFER

- Woofer 6-1/2" (165 mm)
- Max power 250 W / Nom. power 125 W
- Frequency response 80 Hz - 6 KHz
- Impedance 2 Ohms

Die cast aluminium basket - Ultra rigid carbon fiber cone - NBR surround - Dual spider - 38 mm Voice Coil, fiber glass former - Oversized Neodymium Multi-Stick Magnetic motor - Machined aluminium phase plug - Gold-plated terminal - Paired products to +/- 1dB.

TECHNICAL SPECIFICATIONS

Component	Woofer	
Max power	250 W	
Nominal power	125 W	
Impedance	2 Ω	
Freq. Response	80 Hz - 6 KHz	
Sensitivity (2,83V/1m)	94 dB	
Magnet	Neodymium	
Magnet size Ø x h	10x 15 x 17 mm	10x 0.591" x 0.669"
Total driver displacement	0.3 l	0.011 cf
Weight of one component	1.81 kg	3.990 lb
Voice coil Ø	38 mm	1.496"
Voice coil height	17 mm	0.669"
Cone	Carbon fiber	



Unit : mm

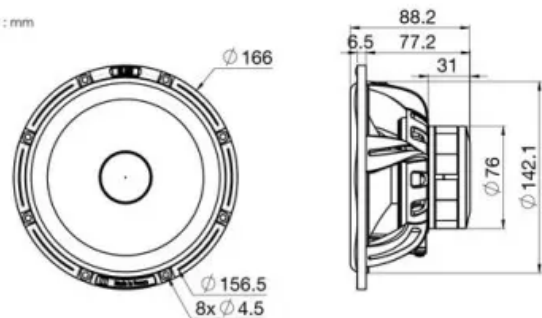

FREQUENCY RESPONSE / IMPEDANCE

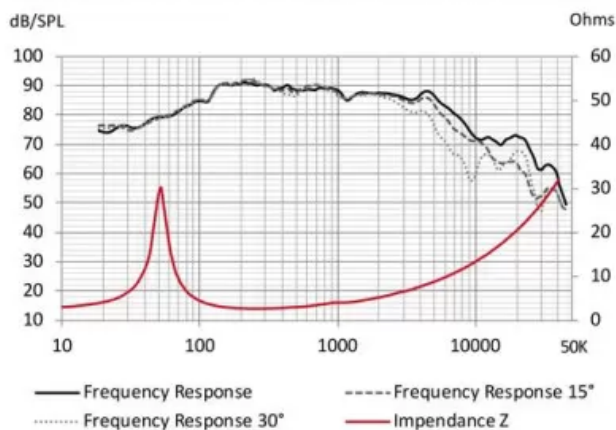

THIELE-SMALL PARAMETERS

Effective Ø (d)	128 mm
Sd	128.68 cm ²
Xmax	6 mm
Re	2.1 Ω
Fs	51.84 Hz
Le	100.07 μH @ 1 kHz
Le	263.46 μH @10 kHz
Vas	12.9 L
Mms	16.99 g
Cms	0,000555 m/N
BL	5.63 Tm
Qts	0.37
Qes	0.40
Qms	4.75
Sensitivity (dB/W/m)	88.1 dB

contact@blam-audio.fr
www.facebook.com/blamaudio

blam-audio.com